



CONTROL PANEL

“50A506” Model Duplex 115/208/230V 1 Phase Control Panel

Features & Benefits

- Circuit Breakers for Pump Circuits
- Definite Purpose Motor Contactors
- Easy to Access Terminal Block
- Usable with 115/208/230 VAC 1PH Power
- Alarm Silence & On-Off-Test Switches
- Externally Mounted Audible Alarm
- Alternating Relay w/Selector Switch
- Pump Hand-Off-Auto Switches
- Pump Running Lights
- Large External Alarm Light
- Control Circuit Fuse Protection
- Ground Lugs
- Color Coded Internal Wiring
- Rugged Weather Resistant Hinged Poly Enclosure w/Sst Latches
- Built and Labeled to UL 508A Standard w/Nema 4x Rating
- Provided with Wiring Schematic and Detailed Connection Diagram for Installer
- Mounting Feet for Enclosure

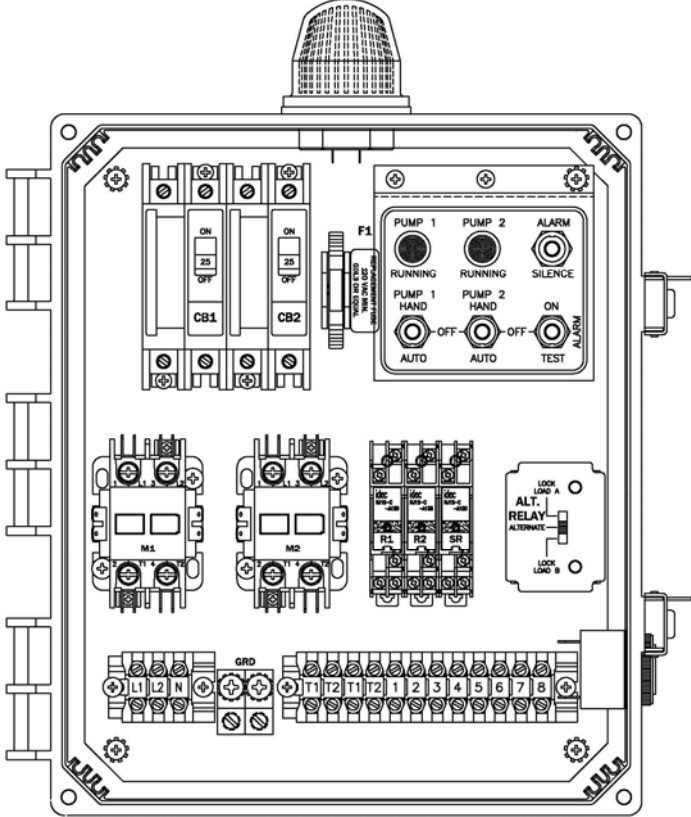

(Standard 50A506 Model Shown)

Available Options(*)

- Fiberglass Enclosure
- IEC Motor Contactors
- Flasher
- Dead Front Inner Door
- Auxiliary Alarm Contacts
- Elapsed Timer Meters
- Event or Cycle Counters
- Mercury or Mechanical Float Switches for the Pumps and High Water Alarm Circuits



*Note: Consult the factory for other available options. Also, some options may require an increase in the enclosure size.



CONTROL PANEL

“50A506” Model Duplex 115/208/230V 1 Phase Control Panel

Panel Dimensions

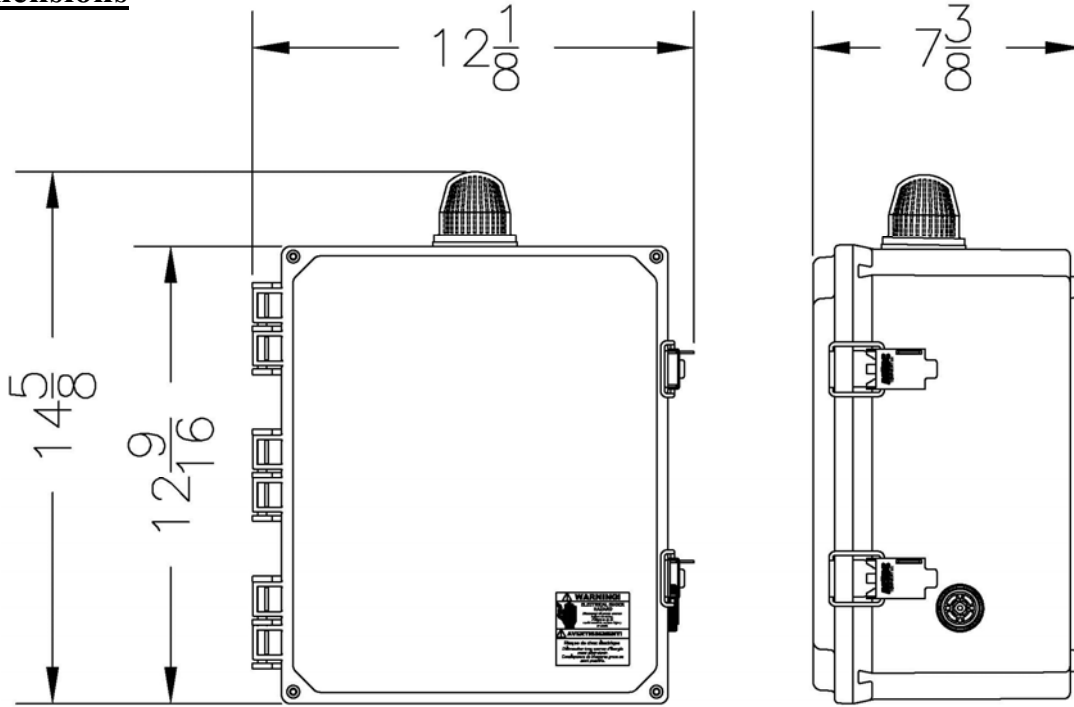

Panel Schematic

