

Take Control.
ION
Technologies

A division of Metropolitan Industries, Inc.



M33V-50V

1 YEAR
WARRANTY



Sump Pump

- Basement Sump
- Dewatering



37 Forestwood Dr., Romeoville, IL 60446
www.ionproducts.net [815] 886-9200

M33V-50V

Sump Pump

System Specifications

Typical Applications	<ul style="list-style-type: none">• Basement sump• Dewatering
Maximum Capacity	M33V: Up to 50 GPM M50V: Up to 70 GPM
Maximum Head	M33V: Up to 21' M50V: Up to 26'
Electrical Data	M33V: 115 V, 1 Ø, 6.5 FLA, 60Hz M50V: 115 V, 1 Ø, 7.0 FLA, 60Hz
Motor Data	M33V: 1/2 HP, 1750 RPM M50V: 1/3 HP, 1750 RPM
Recommended Minimum Basin Size	18" x 30"
Automatic Operation	V: Vertical switch
Materials of Construction	Cast iron
Impeller	M33V: Thermoplastic, 6-vane M50V: Cast iron, 6-vane
Power Cord	10'
Discharge Size	1-1/2" NPT
Solids Handling	1/2"

Pump Dimensions

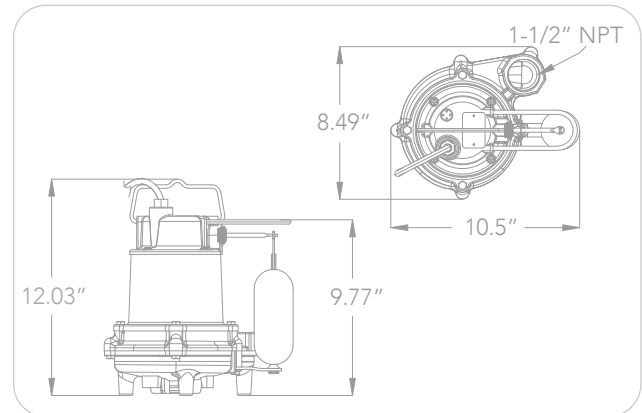

Pump Performance

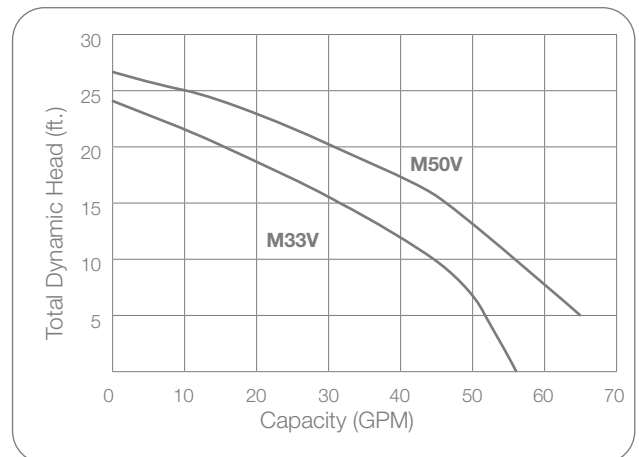

Features

- Carbon ceramic mechanical seal
- Oil-filled continuous duty PSC motor
- Upper and lower ball bearing construction for smoother operation
- 1 year warranty